



BROADCAST PENDANT

FEATURES: Australian designed and manufactured the broadcast pendant has been produced from extruded aluminium for optimum performance. Ideal for technical projects when beam angle and glare control is important. The pendant utilises the latest Stark LED boards offering an efficacy of up to 187 lm/W. Various options available on request.

The Broadcast pendant was originally created for editing and operational rooms for film, TV and radio. Using a 60° frosted lens / 5000k colour temperature / 250mA with a Dali driver. With fully adjustable deep barn doors offering a narrow 2° to 83° beam angle with excellent cut off.

The standard version comes with frosted diffuser running at 350mA is ideal for commercial retail and hospitality applications.

- High output 350mA as standard. 250mA on request where low lumen output is required
- Dimming. As standard DALI / DSI / SWITCH DIM
- Colour temperatures 3000K, 4000K and 5000K
- Efficacy of up to 187 lm/W
- Lamp life 50,000 hours
- Small colour tolerance MacAdam 3
- Max length per pendant 3.2m
- Suspension drop max 5m

COLOURS: Black -2

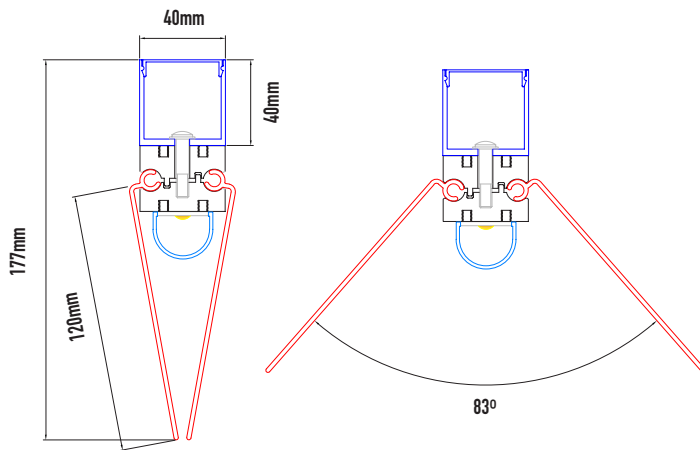

ADJUSTABLE BEAM ANGLE



STANDARD - FROSTED DIFFUSER

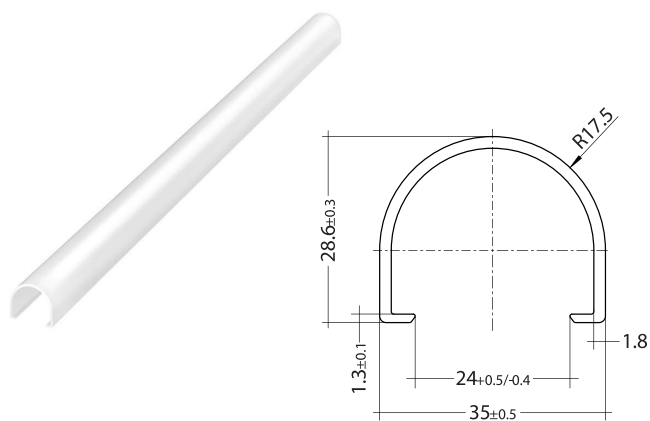

CUSTOM - SEMI TRANSPARENT LENS

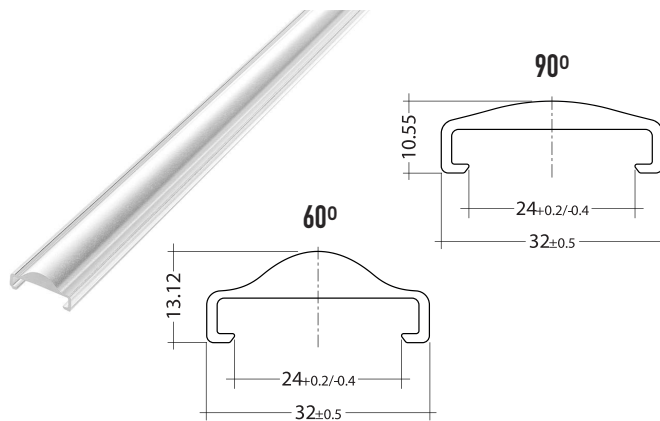

CODE	WATTAGE	COLOUR TEMP	CHIP LUMENS	DIMENSIONS	SUSPENSION DROP
BRD15	40W	3000K	6720	1500mm length	1500mm
		4000K	7030		
		5000K	7180		
BRD12	32W	3000K	5380	1220mm length	1500mm
		4000K	5620		
		5000K	5740		
BRD09	24W	3000K	4030	940mm length	1500mm
		4000K	4220		
		5000K	4310		