



ROX IP65

- FEATURES:**
- Exterior inground uplight IP65 MR16
 - Marine grade stainless steel trim (SS316) 304 stainless steel body comes with polycarbonate mounting tube
 - Clear glass lens
 - Requires 12V remote ferromagnetic transformer
 - 3000k as standard, 4000k available on request
 - Ideal for commercial or residential applications and exterior accent lighting

- COLOURS:**
- | | | |
|--|-----------------|-----|
|  | Stainless Steel | -SS |
|  | White | -3 |
|  | Black | -2 |

- ACCESSORIES:**
- Honeycomb filter (AL20)
 - Transformer 12V IP67 - 50VA, 100VA, 200VA, 300VA and 400VA

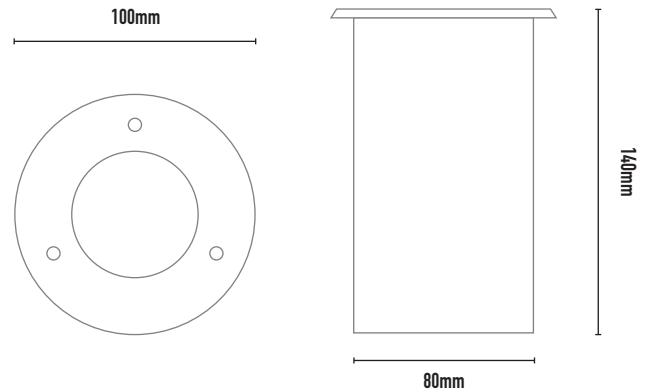

| CODE | WATTAGE | LAMP TYPE | COLOR TEMP | BEAM ANGLE | LUMENS | DIMENSIONS |
|---------|---------|-----------|------------|-----------------|--------|---------------|
| MS40902 | 5W | MR16 LED | 3000K | 25°, 45° or 60° | 320lm | 140mm x 100mm |