

ELIPSO SERIES II

- FEATURES:**
- Australian designed and manufactured
 - For integral or remote transformer
 - Adjustable 180° or 359° swivel
 - Mounting: ceiling plate (CP2), hook clamp (HC), 1C track adaptor (GB67), 3C track adaptor (3C), fixed point mount (FX)
 - Two way 20° tilt adjustment
 - Multiple lamp options
 - Easy lamp change
 - Ideal for applications such as retail, gallery and entertainment lighting

- COLOURS:**
- Black -2
 - White -3
 - Silver -6
 - Custom -5

- ACCESSORIES:**
- Glass filter (GF)
 - Anti-glare louvre (DG)
 - Gobo holder (GH9000)

(shutter blades and twin adjustable lenses create various beam shapes)

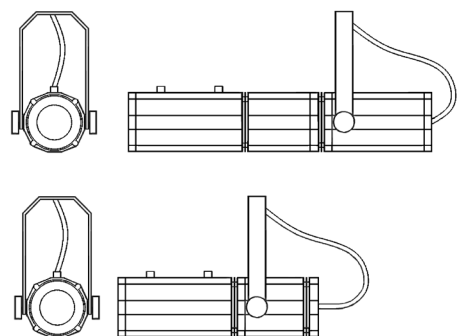

CODE	WATTAGE	LAMP TYPE	DIMENSIONS
EL900TR	20W-50W	12V 10° MR16 (remote trans)	145mm x 245mm
EL900TI	20W-50W	12V 10° MR16 (remote trans)	145mm x 245mm